

JCSDA, Vol. 1, No. 1, 59–74
DOI: <https://doi.org/10.69660/jcsda.01012404>
ISSN 2959-6912

Enhancing Mobility and Safety: A Smart Walking Cane for Visually Impaired Individuals with Ultrasonic Sensor, Infrared, and GSM Module

Anteneh Tesfaye Alemneh

*Department of Electrical and Computer Engineering,
Artificial Intelligence and Robotics Center of Excellence,
Addis Ababa Science and Technology University, Addis Ababa, Ethiopia
anteneh.tesfaye@aastu.edu.et*

Traditionally, visually impaired individuals have relied on conventional walking canes to detect obstacles in their path. However, these canes have limitations in terms of efficiency. This paper focuses on the design and implementation of an electronic travel aid for visually impaired pedestrians, utilizing ultrasonic sensors, infrared technology, and a GSM module. The smart cane integrates ultrasonic sensors and IR technology to detect obstacles using ultrasonic waves and IR signals. When obstacles are detected, the sensor relays this information to a microcontroller (Atmega328P). The microcontroller processes the data and determines the proximity of the obstacle. If the obstacle is not closed, the system remains inactive. However, if the obstacle is close, the microcontroller activates a buzzer, generates continuous alarming sounds, and vibrates a motor, enabling the user to navigate the path more easily. Additionally, the system is equipped with a GSM module, allowing it to send SMS notifications to designated contacts in case of emergencies. By pressing an emergency button, a message is sent to a specified phone number. This integrated system provides both obstacle detection and emergency SMS notifications. The successful implementation of the system demonstrates its effectiveness and efficiency.

Keywords: Ultrasonic Sensor, Infrared Sensor Microcontroller (AT mega 328P), smart blind walking stick.

1. Introduction

Lack of neurological or visual perception is a condition known as blindness [1]. Total blindness is the complete absence of visual light perception, while partial blindness is the absence of integration in the growth of the optic nerve or visual center of the eye. Around 295 million people are regarded as having vision impairments worldwide. According to estimates from the World Health Organization (WHO) published in 2022, 43 million of them are blind and the remaining people have very poor vision [12][1].

A form of visual impairment affects about 26.3 million people in the African region [1]. Of these, 5.9 million are thought to be blind and 20.4 million have weak vision. According to estimates, Africa is home to 15.3 percent of the world's blind people [1].

The World Health Organization (WHO) estimates that more than 1.8 million Ethiopians, or 1.6 percent of the total population, are blind and that 4.1 million people, or 3.7 percent, have impaired vision [1]. This is significantly higher

than the global averages of 1.2 and 3.4 percent. Imagine entering an unfamiliar location [18][10]. One has to request assistance to get somewhere. But what if the individual is blind the Person has to completely depend on other people to reach the destination [15][2]. The lack of visual senses causes many social and psychological challenges that prevent visually impaired people from having a normal quality living. They do not have much privacy and independence since they are accompanied by a member of the family most often [13][14]. Due to the "unsafe" outdoor environment, they tend to not leave their house very frequently on their mobility aids are an important part of the visually impaired [11][9]. Nowadays many types of mobility aids are used the visually impaired people. However, the majority of the population that are visually impaired often use the widely known support cane. The cane requires guidance from people on some occasions and depends on hitting objects to identify their locations.

This research design simulates and implements a portable unit (stick) for them for easy usage and navigation in public places. It is a walking stick normally used by the blinds. But ultrasonic and IR-based smart visually impaired walk canes are fully automated, easy to maintain, have low power consumption and can operated easily. The walking stick mentioned above is a stick that consists of a circuit board that contains a microcontroller (AT Mega 328P), different sensors and a buzzer. Blindness is one of the most dangerous kinds of disabilities, and because of this many engineers have been developing some aids that assist visually impaired people in the whole world. One of the basic and the most available kind of aid that is known to us is the white stick/cane. This cane is developed to operate by giving an echo from the road when the blind is walking. But this takes some time for the blind to train and incorporate the echo with his ears. Even if after some time with practice it can be easily thought it's inaccurate. However, nowadays there are some improvements on the white stick making it more comfortable to use and most importantly making it electronic and automatic.

2. Motivation

Blind individuals possess a remarkable motivation to navigate the world around them, despite the challenges they may face. They exhibit a strong drive to enhance their independence and overcome obstacles. While it is true that some blind individuals may benefit from occasional assistance, it is essential to recognize their determination to lead fulfilling lives and their eagerness to embrace innovative solutions that promote their mobility.

3. Statement of the problem

The White Cane and guide dogs are two of the most popular current options that assist the sight-impaired in their daily lives. But each of them has flaws of their own. The guide cane sometimes needs people's assistance, relies on hitting objects to locate them, and identify their location, and has a range that is limited by the user's

ability to notice overhanging obstacles and must be stored safely in public places. Due to its inherent limitation, the long cane does not protect the body above waist elevation consequently there is no guarantee that the presence of obstacle does not identify an approaching object such as bicycles, low-slung signposts, utility boxes, tree branches, overhanging wires, can be detected by the blind person in time to avoid the collision. Similarly, the guide dog is a costly solution and requires routine care. Furthermore, many public transport facilities and areas like buses and moles prohibit pets from entering, creating problems for guide dog owners. Therefore to remove the above problems this paper proposed a smart electronic device that is portable and alerts the users of obstacles in their path when blind individuals with getting around.

Hence, considering the above main drawbacks and challenges the visually impaired people face regularly, there is no doubt that there is a great necessity to address this problem worldwide.

4. Objectives

4.1. General objective

The general objective of the paper is to design, simulate and implement ultrasonic and IR-based smart Walking Cane for visually impaired people.

4.2. Specific objective

The specific objective of this paper

- To develop a system that effectively detects and alerts the user about potential obstacles, such as walls, furniture, and other physical impediments.
- To enhance the self-esteem of visually impaired individuals by providing them with a reliable and intuitive smart guide cane system.
- To optimize the cost-effectiveness of the system without compromising its functionality and quality.
- To create a system capable of identifying and notifying the user about specific challenges they may encounter, including narrow passages, staircases, and water hazards.
- To promote greater independence for visually impaired individuals through the implementation of the smart Walking Cane system.
- To simplify and improve the daily lives of visually impaired individuals by offering a user-friendly and intuitive interface.
- To make blind people's lives easier and more comfortable.
- To design and simulate a smart walking cane that comprises IR and ultrasonic sensors.
- To develop a prototype of the smart walking cane.
- To test and validate the prototype's accuracy and precision.

5. Literature review

Electrical engineering senior design project final report, spring 2013 [3]. The project aims to build the "self-energized smart vision stick" using modern technologies for visually impaired individuals while maintaining the benefits of the white cane and guide dogs. The self-powered smart vision stick is a clever device that can improve the lives of individuals who are blind and boost their everyday independence, privacy, and safety. With the help of the vision stick, the instrument uses distance sensors to measure the distance of surrounding objects and warn the user as necessary. It includes an emergency system that can offer effective techniques to save the user in perilous circumstances. The system is self-energized using embedded electric generators, as the project name suggests, and provides a useful alternative for low-charge scenarios away from the electric grid.

A project known as "Assistive cane for visually-impaired people" was proposed in [4]. It functions as a cane detecting surrounding objects and alerting the user using ultrasonic sensors. A distinctive feature in the cane's ability to detect if there is water collection in a specific area using water sensors. The cane is designed to be foldable such that it can be carried around more conveniently when not used. Moreover, the cane's design has basic functionality and does not have additional distinguishing features.

A technology called "GPS talking" was proposed in [5]. To aid a VCP in independent navigation. This device lacks the capability of obstacle detection and is instead mostly a localization-based aid. It comes equipped with a GPS receiver, a PIC microprocessor, a voice recorder, a liquid crystal display (LCD), a microphone, and a headset. The microcontroller compares the position coordinates with the predetermined coordinates after receiving them from the GPS receiver. It plays an audio message from the voice recorder and alerts the user through the headset if the coordinate range matches. The designer uses the LCD to read the coordinates for the present place.

A prototype known as "substitute eyes for the blind" was put forth in [6]. In which the embedded system primarily aids in obstacle detection and the APP aids in navigation. Three mobile vibration motors, two HC-SR04 ultrasonic sensors, and a TI MSP430G2553 microcontroller make up the system. The suggested device is more lightweight and less expensive, but it must be held between the fingers, which is uncomfortable for prolonged use.

A walking stick prototype that enables the VCP to move on its own both inside and outside was proposed in [7]. An SRF02 sonar sensor is integrated inside the walking stick for obstacle detection, and RFID and a GPS module are employed, respectively, for indoor and outdoor location detection. Sending alert messages to contacts who have already been registered also uses a GSM module.

A technology termed "virtual eye" was proposed in [8]. To improve a VCP's movement in a certain area. The system's components are an ultrasonic detector for bar escape, an Arduino microcontroller for reprocessing the signal admitted by the

detectors, and a Raspberry Pi acting as a speech synthesizer to alert the VCP to detected obstacles. The design consists of a wearable cap, a mini-hand stick, and shoes. The sophisticated technology can identify obstructions in the doper's front, back, left, and right directions.

As a result, this research suggests a smart walking stick for the blind that uses IR and ultrasonic technology and offers several useful capabilities. For this system, an AT Mega 328P microcontroller was paired with a single board to increase its dependability, power, and effectiveness. It can identify obstacles at a distance of up to 80 cm (up to 2 m), as well as the upper and lower right and left body portions and water puddles. It also offers capabilities for communication and localization in emergency scenarios. The user triggers the emergency system, which then sends an SMS to a preset number that is a close relative of the user. This indicates that fewer components are needed to create this system's simplicity, lightness, low power usage and affordability.

6. Methodology

The suggested system focuses on assisting visually impaired people with navigating in their daily lives and makes their lives simple and easy. The suggested device proposes to alert visually impaired people to things in their path using motor vibration and voice output. This method of object detection makes use of four ultrasonic sensors positioned in various directions, an IR sensor that can identify minor obstructions on a surface, and a water sensor that can detect standing water on a surface while a blind person is working nearby safely. The system will use ultrasonic sensors connected to an AT Mega328p microcontroller, and the distance to the object will be calculated from the ultrasonic signals that are detected. The microcontroller will retrieve the voice output and motor vibration based on the signals it has processed. Thus, the device will enable them to easily navigate their environment without asking for assistance from anybody else.

Figure 1 below is the block diagram of the smart Walking Cane for visually impaired people the system shows the various parts and components used the device uses the sensors to detect obstacles within the designed range and then it gives vibration and alerts in the form of sound to the visually impaired man to avoid the obstruction.

7. System design and description

An Ultrasonic and IR-based smart walking Cane for visually impaired people is shown in Figure 2. On the stick are four ultrasonic sensors with a range of 80cm to 200cm adjustable to various ranges. Additionally, a low-side infrared sensor is used to detect obstructions that are 10 to 20 cm away. A switch that, in the worst-case scenario, can be pressed with the thumb that enables a blind user to call for assistance by sending a general message to a saved mobile number that reads, "I'm in danger Please help me!" The two vibration motors are worn on the wrist like

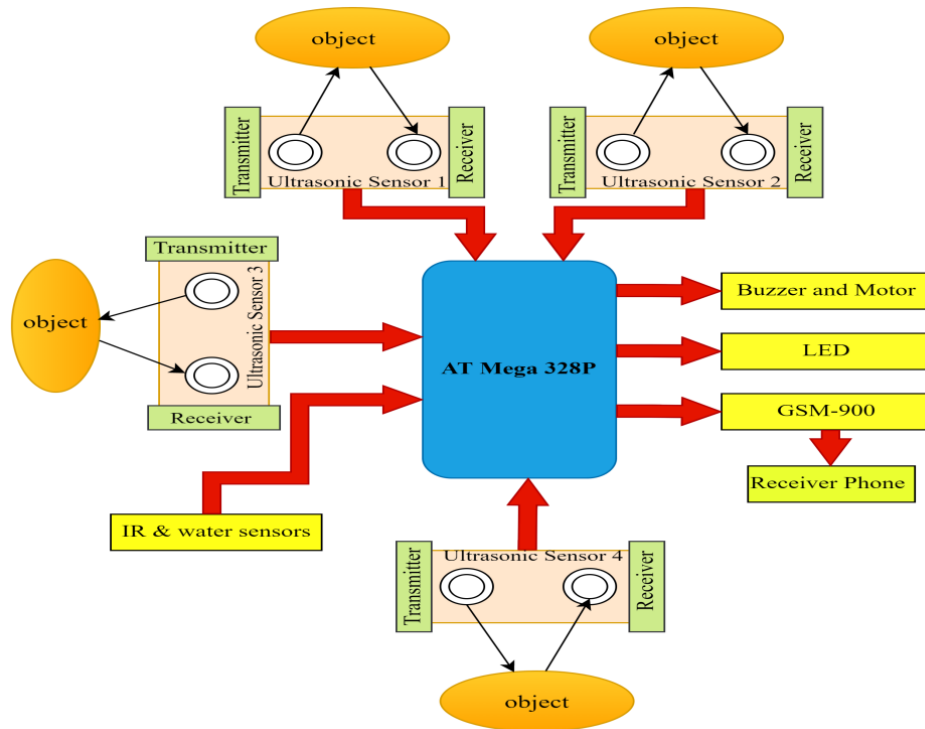

Fig. 1. Design block diagram

watches, and information collected by the sensors reveals the vibration motors' direction of movement for the blind individual. Accordingly, when the right-direction ultrasonic sensor detects an obstruction, the left-side motor vibrates on the arm and the user moves in the left direction. Conversely, when the left-direction ultrasonic sensor also detects an obstruction, the right-side motor vibrates on the arm and the user moves in the right direction. The upper-side ultrasonic sensor locates the upper portions of barriers, such as tree branches. The Upper-side obstruction is the most hazardous for blind people. The blind cane's motor will vibrate heavily in this situation. A controversial beep sound is also produced by the buzzer. When going straight the motor on the stick will vibrate when a barrier is detected by the ultrasonic sensor. The buzzer will emit a beep sound when the water sensor detects water. The GSM 900 module and microcontroller circuitry are both present in the smart cane. A complementing system that may provide a trustworthy distance measurement is made possible by the cooperation of the ultrasonic and IR sensors.

7.1. Software unit

The Arduino LDE program is used to code the entire procedure. It enables the AT

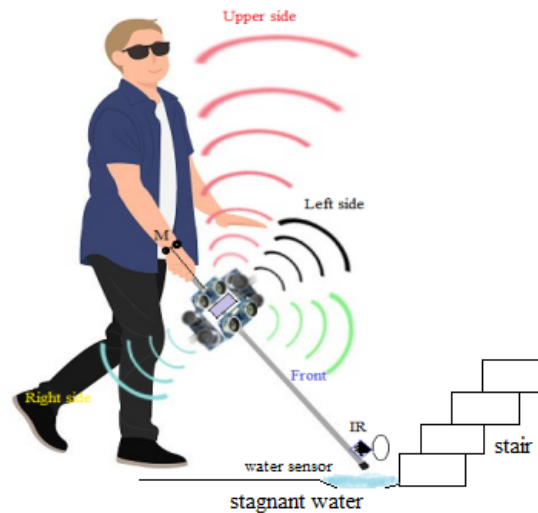

Fig. 2. Visually impaired man with a smart walking cane.

mega 328P to complete tasks according to the directions provided in the code. Additionally, it transforms the ultrasonic signals into numerical values that represent the separation from the detected object.

The AT mega 328P IC receives the written code and uploads it. The electronics circuit is constrained on proteus then uploads the code hex file to finally simulate the ultrasonic and IR-based smart blind walking stick. Make the circuit on Eagle software first, then transfer the circuit to PCB Layout, for PCB preparation.

7.2. Hardware Unit

Ultrasonic Sensor: These sensors have a range of 2cm - 400cm. It is made up of two parts: a transmitter and a receiver. The ultrasonic signals are transmitted by the transmitter and received by the receiver. The signals are then sent to the microcontroller to be processed further

At Mega 328p Microcontroller: One of the high performance AVR technology microcontrollers with a lot of features and pins is the ATmega328p. It is built with an RSICCPU and 8bit CMOS technology, which improves performance while in built temperature sensors and auto naps increase power efficiency. Multiple programming techniques and inherent safeguards on the ATmega328P IC enable engineers to prioritize this controller for various applications[16]. The ATmega328P microcontroller has been increasingly used recently because the IC supports numerous modern-era connectivity techniques for other modules and microcontrollers themselves.

GSM System: A common GSM/GPRS module used in many mobile phones and PDAs is the SIM900A. The Internet of Things (IoT) and embedded applications can both be developed using the module. The SIM900A is a dual-band GSM/GPRS

engine that operates on the EGSM 900MHz and DCS 1800MHz frequencies[17].

Piezo Buzzer: Piezoelectricity refers to a material's capacity to produce an electric field or electric potential in response to the application of mechanical stress. This property is most prominent in crystals and some ceramics, including bone. If the material is not short-circuited, the stress applied causes a voltage to develop across it.

IR Sensor: The IR sensor, also known as an infrared sensor, is a type of electronic part that emits or detects IR radiation to identify specific features in its environment. The heat and motion of a target can also be detected or measured using these sensors. The IR sensor circuit is a crucial component in many electrical gadgets. The visionary senses used by humans to detect barriers are similar to this type of sensor.

Water Sensor: A technology used to measure the water level for a variety of applications is called a water sensor. The water level sensor's operation is rather simple. In a potentiometer-like variable resistor, the series of exposed parallel conductors together change resistance in response to the level of the water.

Vibrating Motor: The little vibrating motor is a brush or core-less DC motor that has an eccentric mass (fan or round form). When the motor is operating, the eccentric's rapid rotation generates centrifugal force, which causes the motor to vibrate. This vibration can be used to alert consumers to new calls or messages

7.3. Detection and alert system

Figure 3 demonstrates how obstacles are located and the user is informed when needed. According to the flow chart, the system starts by powering the microcontroller and then loops indefinitely. The signals are then sent into the microcontroller by the four ultrasonic sensors in the loop, which employ the ultrasonic transceivers to continuously detect the objects nearby.

There are five stages in the system implementation stage. The fourth component is for detecting obstacles, while the other is for receiving location data such as readings from water sensors. The AT Mega 328p microcontroller and other modules are powered by the power supply, which initializes and activates the system as a whole. Figure 3 demonstrates the flow chart for how the obstacle detection function is implemented, it will be detailed in more detail below.

The echolocation principle, which a bat employs to find its prey, is the same principle that the ultrasonic sensor uses to do the same. Beyond the range of human hearing, the ultrasonic sensor sends out an ultrasound wave at the speed of sound and then waits for the echo wave to come back.

8. Working principles

In the system, obstructions are detected using ultrasonic sensors. The sensors have a threshold limit, and if an obstruction is detected within that range, the buzzer will beep. The ultrasonic sensors produce noises that are detectable to machines

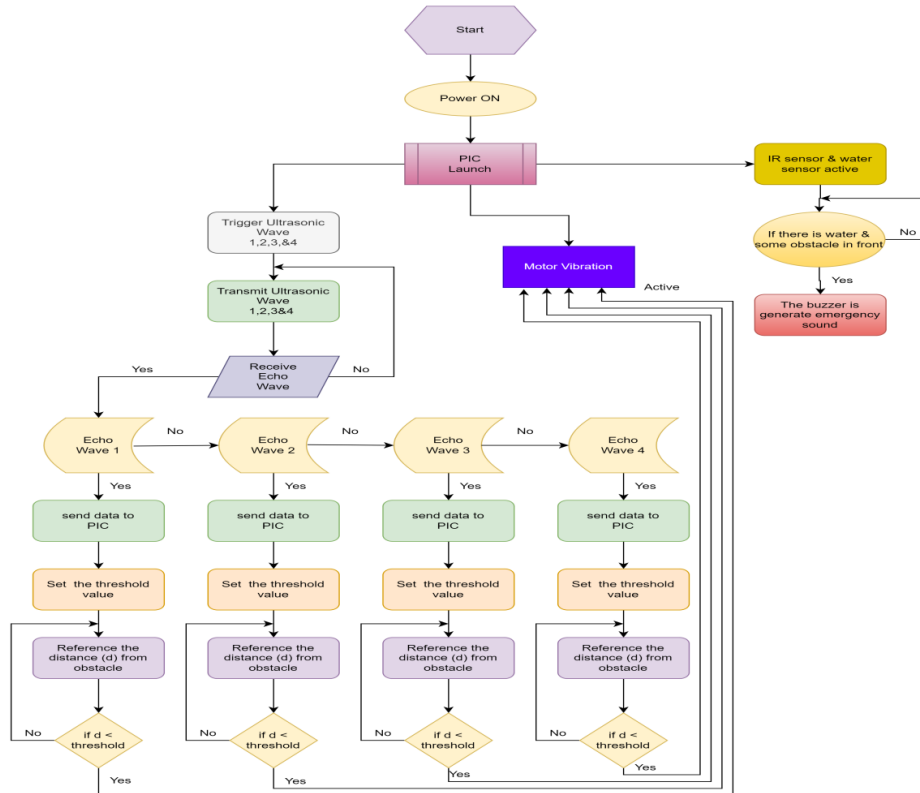

Fig. 3. Detection and Alert System Flowchart.

but not to human hearing (above 20 KHz and approximately 40 KHz). Once the distance to the obstacle is determined, the conditions are examined. The sound waves hit the obstructions and returned to the detector. To operate a buzzer, the signal is next transmitted to a microcontroller. We used three light-emitting diodes to simulate the proximity of the person to the barriers and to demonstrate this, we provided a range of distance. However, because the person is vision impaired, light emitting diodes are not used in the hardware implementation. In addition to all of this, we have incorporated a GSM module that allows us to send an SMS message to a visually impaired person's family or close friends in an emergency so they may come and assist him. As a result, we have here demonstrated the hardware implementation and design of the cane simulation on Proteus.

8.1. PCB preparation

Design a PC Board with Eagle's free version, and the shield will fit straight onto the Arduino Uno. After creating the board layout, take note of the area taken up by

the dual in-line IC socket. The completed PCB. It used a 16MHz oscillator, which is easily replaceable using a crystal and two capacitors. The power switch is connected in such a way that it turns off the +5V. Using the PCB, the circuit is quickly built. Modifications were made to the common header pins used to connect the shield to the Arduino. Finally, we labeled the LED's and the programming header. When the circuit design is complete, it is covered by the PCB layout, whereupon the pin configuration or line overlapping is changed to provide the ideal PCB layout. Then print the design on water-resistant paper, prepare a pure copper board, and transfer the printed layout using a clothes iron to the copper bore. Following the transfer process, a concentrated Hydrochloric acid or Nitric Acid is made, and the copper board is placed in it. After a short time, the chemical removes the copper board's unpainted portions. Then drill the board, install the covert component, and solder the latter using a soldering iron and lid to produce the result depicted in Figure 4.

Hard Ware Constructions PCB

HARDWARE CONSTRUCTION SMART STICK: After uploading the written code on the microcontroller, all the internal and external components of the hardware are integrated and the view of the smart walking cane will look like the following in Figure 6.

9. Results

The result in our simulation and implementation works fine as we expected. From our simulation and implementation result, we have observed that when the obstacles are above two meters the stick has no response and when it's two and three meters the blue LED will give a signal. In the range of 0.8 meters to 1.2 meters, the stick gives a sign that the person is going closer to the forbidden zone and we indicated that by the yellow LED light so that the person has to be careful in his way. Finally, when the person is almost in the forbidden region that is in front of the obstacle then immediately the red LED light will turn on and together with the red light the buzzer will start to give a beep sound and the motor vibrates of course will be suitable for the human ear. Thus in this way, the stick can detect an obstacle. Hardware implementations of having the components especially ultrasonic sensors, IR sensors, water sensors and GSM modules are available. So we are forced to have a simulation and implementation. In addition to the above result we have also seen the result from the GSM module that it sends an SMS message when an emergency case occurs.

9.1. Test result/validation

Objects with varied physical features, such as wood, plastic, glass, pine, huge flowers, concrete walls, stairs, and so on, are set at a distance apart and the distance is measured using ultrasonic and infrared technology. For each object, we took six distinct readings. According to the observation table, the output for all objects is nearly identical. This property of ultrasonic sensors makes them superior to IR

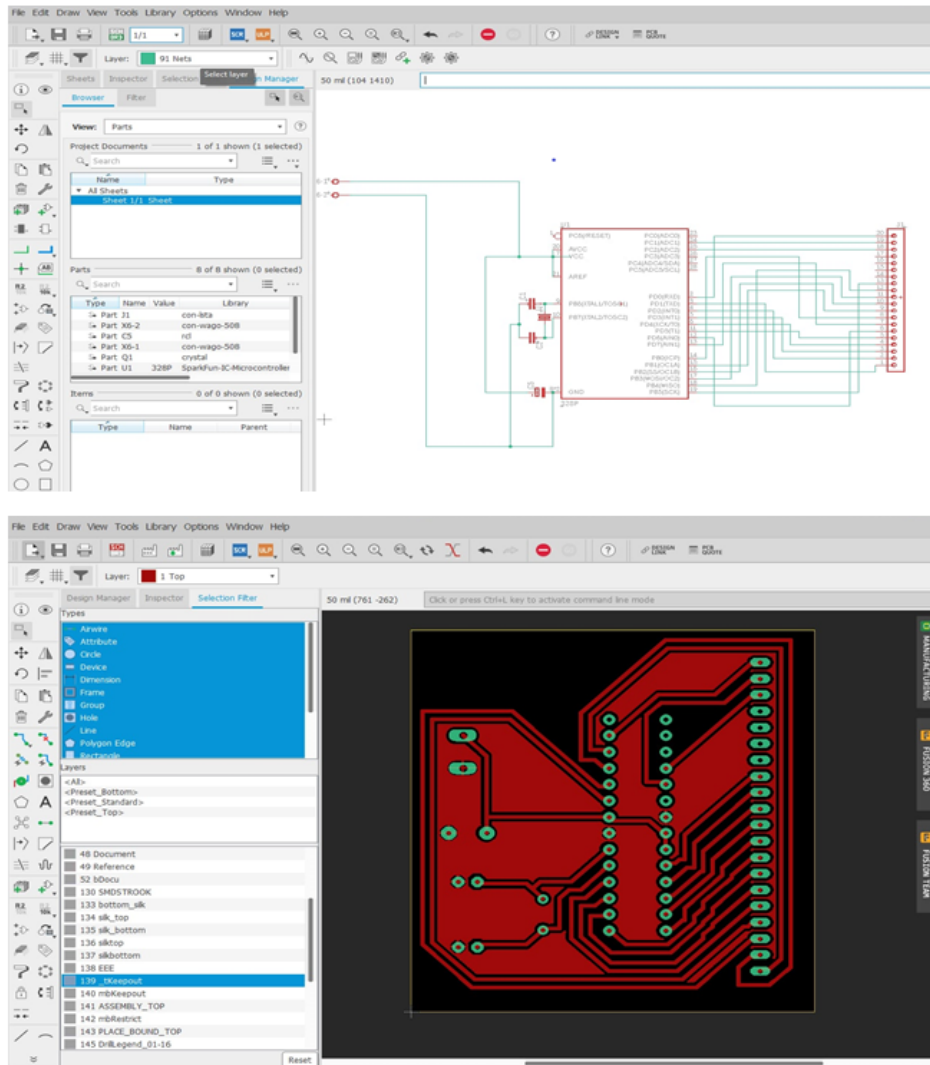

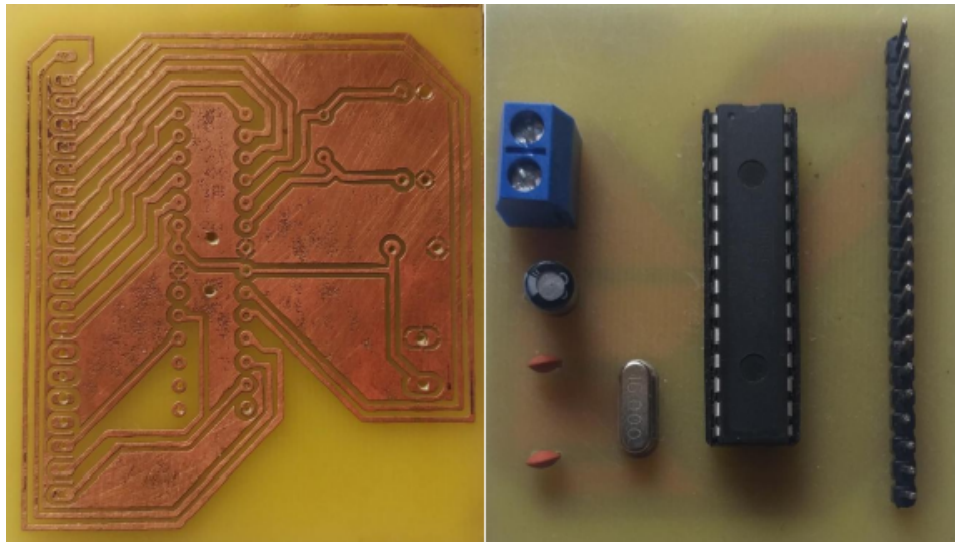

Fig. 5. PCB Board-Mounted Component.



Fig. 6. Hard Ware Constructions.



Fig. 8. Different Material Test Result.

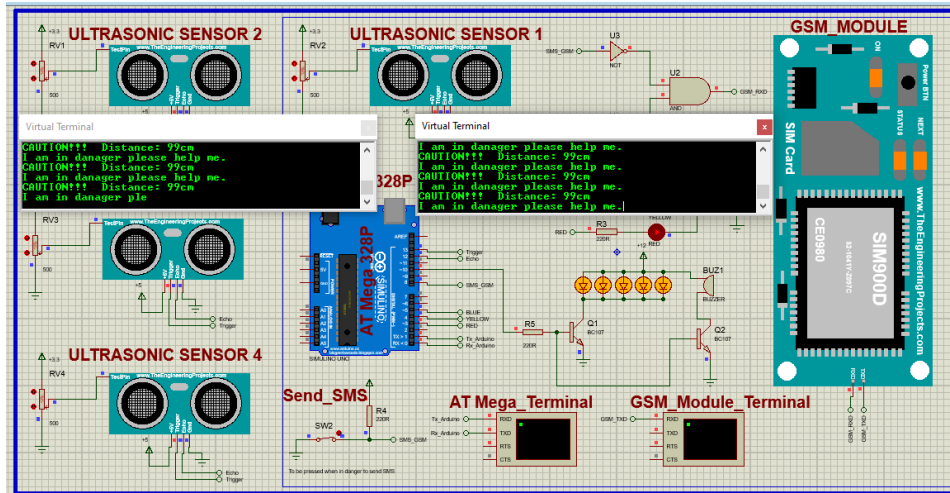

Fig. 7. Sending SMS notification.

Obstacle	Test 1 from 85cm	Test 2 from 80cm	Test 3 from 60cm	Test 4 from 40cm	Test 5 from 20cm	Test 6 from 10cm
Plastic	0	10	10	10	10	10
Wood	0	10	10	10	10	10
Glass	0	10	10	10	10	10
Huge flower	0	7	10	10	10	10
Total per-cent	0	92.5	100	100	100	100

Table 1. Hardware Test Result from Front, Left and Right Direction

To evaluate the sensor’s performance with various items, we ran hardware implementation with several obstacles placed at different directions front, left and right on various distances, as shown in Table 1 below.

The reason why set the starting point as 85cm for the testing is because the distance set when coded is 80cm. Even more than this, if the distance is increased and the code is coded, it will be difficult for a user with vision problems to use it, because if the sensing distance increases, it will detect harmless obstacles from the left and right, and there will be constant vibration or sound, so it will be difficult to decide where to go.

To verify the sensor’s performance with various items, we conducted a hardware implementation with several obstacles positioned at the top of the most dangerous for visually impaired people. It was tested at various distances, as indicated in the

Obstacle	Test1 from 1.5m	Test2 from 1.2m	Test3 from 80cm	Test4 from 60cm	Test5 from 40cm
Plastic	0	10	10	10	10
Wood	0	10	10	10	10
Glass	0	10	10	10	10
Tree branch	0	9.5	10	10	10
Cars/Tracker	0	10	10	10	10
Total percent	0	99	100	100	100

Table 2. Hardware Test Result in Top Direction

table below.

Table 2: Hardware Test Result in Top Direction



Fig. 9. Test Result on Stairs.

We conducted a hardware implementation with multiple obstacles put in the bottom direction. It was tested at various distances, as given in the table below, to evaluate the IR and water sensors' performance with accumulated road water and stairs. If the water sensor comes into contact with water that has been stored in a direct path, it will emit a direct sound. It is not affected by distance.

The Infrared sensor effectively detects obstructions and staircases, yielding the expected results.

9.2. Discussion

To begin with, each component was tested on its own by running the code for each function and examining the outcomes and performance. We then unified the scripts for each function, ran them all at once, and integrated every part into the walking stick for use. This system has this feature, just like other systems that employ GSM, an emergency button, or other components to contact family members. We

Obstacle	Test1 from 35cm	Test2 from 30cm	Test 3 from 20cm	Test 4 from 15cm	Test 5 from 10cm	Test 6 from 5cm
Small Stones	0	0	10	10	10	10
Stair	0	0	10	10	10	10
Water ditch	0	0	10	10	10	10
Curve Stone)	0	0	10	10	10	10
Total percent	0	0	100	100	100	100

Table 3. Hardware Test Result in Bottom Direction

made an effort to use a few smaller electronic components, mainly to cut costs and complexity. To foresee any hazardous scenarios that the blind person may encounter, we want to gather data in the future about the types of barriers that the user has noticed.

10. Conclusion

The main purpose of this research was to produce a simulation and implementation that can detect objects or obstacles in front of users and feed warnings back in the form of sound and motor vibration to users. Based on the problems of the existing white cane sticks, this research presents enhanced electronic aid using the latest technology by using ultrasonic sensors, infrared sensors, water sensors and GSM modules. It is constructed with the greatest accuracy so that blind people can move from one place to another without other help. The developed research gave good results in detecting obstacles spaced at a distance in front of the user and also the obstacles which are in the simulation and implementation. The results were as expected, and there are still some considerable adjustments that can be made with more time and resources to create a custom walking stick for the blind having recent technology like GPS and some more applications like vehicle detection, slippery floor, oncoming vehicle detection and fire or smoke alarm also be included.

References

1. Organization W. H. (2021). Available online: <http://www.who.int.>), pp. 274–276, IEEE, 2021. accessed on 14 September 2021,”
2. Brady E., Morris M. R., Zhong Y., White S., and Bigham J. P.. (2013). Visual challenges in the everyday lives of blind people. Proceedings of the SIGCHI conference on human factors in computing systems, pp. 2117–2126.
3. Mohammadi M. H., Al Ameri S., and Ziaei S. (2013). Eece498-electrical engineering senior design project final report spring 2013.
4. Kanwal K., Ehsan S., and Clark A. F. (2011). Are performance differences of interest operators statistically significant? International Conference on Computer Analysis of Images and Patterns, pp. 429–436, Springer.
5. Morad A. H. (2010). Gps talking for blind people. Journal of emerging technologies in web intelligence, vol. 2, no. 3, pp. 239–243.

74 REFERENCES

6. Bharambe S., Thakker R., Patil H., and Bhurchandi K. (2013). Substitute eyes for blind with navigator using android,” in 2013 Texas Instruments India Educators’ Conference, pp. 38–43, IEEE.
7. Sangami A., Kavithra M., Rubina K., and Sivaprakasam S. (2015). Obstacle detection and location finding for blind people. *International Journal of Innovative Research in Computer and Communication Engineering*, vol. 3, no. 2, pp. 119–123.
8. Sharma P., Shimi S., and Chatterji S. (2014). Design of microcontroller based virtual eye for the blind. *International Journal of Scientific Research Engineering & Technology (IJSRET)*, vol. 3, no. 8, pp. 1137–1142.
9. Chaitrali S. K., Yogita A. D., Snehal K. K., Swati D. D., and Aarti V. D. (2015). An intelligent walking stick for the blind. *Int. J. Eng. Res. Gen. Sci*, vol. 3, pp. 1057–1062.
10. Sahoo N., Lin H.W., and Chang Y.H. (2019). Design and implementation of a walking stick aid for visually challenged people. *Sensors*, vol. 19, no. 1, p. 130.
11. Swain K. B., Patnaik R. K., Pal S., Rajeswari R., Mishra A., and Dash C. (2017). Arduino-based automated stick guide for a visually impaired person. *IEEE International Conference on Smart Technologies and Management for Computing, Communication, Controls, Energy and Materials (ICSTM)*, pp. 407–410.
12. Therib M. A. (2017). Smart blinding stick with holes, obstacles, and pond detectors based on a microcontroller. *J. Babylon Univ. Eng. Sci*, vol. 25, pp. 1759–1768.
13. Saaid M. F., Ismail I., and Noor M. Z. H. (2009). Radiofrequency identification walking stick (rfiws): A device for the blind. *5th International Colloquium on Signal Processing & Its Applications*, pp. 250–253, IEEE.
14. Agarwal A., Kumar D., and Bhardwaj A. (2015). Ultrasonic stick for the blind. *International journal of engineering and computer science*, vol. 4, no. 4, pp. 11375–11378.
15. José J. , Farrajota M., Rodrigues J. M., and Du Buf J. H. (2011). The smart vision local navigation aid for blind and visually impaired persons.
16. Sunehra D. and Goud V. S. (2016). Attendance recording and consolidation system using Arduino and Raspberry Pi. *International Conference on Signal Processing, Communication, Power and Embedded Systems (SCOPES)*, pp. 1240–1245, IEEE.
17. Vedder K. (2001). The subscriber identity module: Past, present, and future. *GSM and UMTS*, p. 341.
18. Apu A. I., Nayan A. A., Ferdaous J., and Kibria M. G. (2022). IoT-based smart blind stick. *Proceedings of the International Conference on Big Data, IoT, and Machine Learning*, pp. 447–460, Springer.